

Evaluation of a Novel Rotor Processor to Manufacture Spherical 100-300 micron Acetaminophen beads, using two methods; Spheronization and Powder Layering.

BRIAN K. JENSEN¹, SHAWN ENGELS¹
¹VECTOR CORPORATION: MARION, IA UNITED STATES

PURPOSE

This study compared two processes used for the rapid production of high active content spherical beads:

1. Spherical Granulation without the use of a core particle, and
2. Dry Powder Layering, utilizing a core particle.

Both approaches use a minimum of a simple binder solution to show the application efficiency, size uniformity, content uniformity and total process time to manufacture spherical beads suitable for coating for modified release.

PROCESS EQUIPMENT

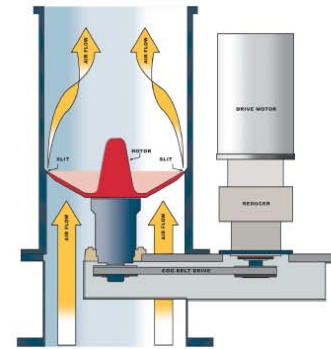

Granurex GX-30

METHODS

Micronized acetaminophen (Mallinckrodt) was used as a model API and was spheronized by direct application of 7.5% povidone binder solution (K29-30) in a Granurex GX-30 rotor processor to make uniform smooth beads. Starch 1500 (ColorCon) and povidone K-12 PF (BASF) were used as processing aids.

In the second approach the GX-30 was used to layer dry micronized acetaminophen on to 100 micron sugar starch cores using a 5% povidone binder solution to produce uniform smooth beads. The product from each process was evaluated for size, sphericity, content uniformity and efficiency.

FORMULATION

	Spherical Granulation	Dry Powder Layering
Acetaminophen	1800	1000
Sugar/Starch cores 30/35	0	2000
Povidone K 29-30	53	29
Starch 1500	100	0
Povidone K-12 FP	47	0

PROCESS CONDITIONS

	Spherical Granulation	Dry Powder Layering	Unit
Batch Size	2000	3029	g
Product Temperature	20	16	°C
Air Volume	10	10	CFM
Spray Rate	10	8	g/min
Solution Volume	700	575	g
Total Process Time	82	100	min

RESULTS

Each method produced beads in the desired size range with surfaces suitable for coating for modified release.

Spheronization was a faster process, used more solution for a given batch size and produced a smaller mean particle size product. The formulation chosen also shows the capacity for high active loading.

Dry powder layering produced a bead with greater size uniformity and a narrower distribution. A smaller core could be selected to make a smaller product or to increase the active loading, but the process time will increase further.

Both processes have very high efficiency in terms of useable fraction and overall losses. The unique rotor geometry and the extremely small rotor / stator clearance allows fine control of micronized actives.

PRODUCT CHARACTERISTICS

	Spherical Granulation	Dry Powder Layering	Unit
Mean Particle Size (X_{50})	110.3	225.2	μ
Range (X_{10} — X_{90})	48.6-233.4	127.7-386.6	μ
Surface Area	211.8	92.9	cm ² /g
Sphericity	87	90	
Active Content	85.7	33	mg/g
Content Uniformity	1.12	1.74	%RSD
Yield	97.2	99.1	%



Spherical Granulation



Dry Powder Layered

GRANUREX GX-30 SPHERICAL GRANULATION

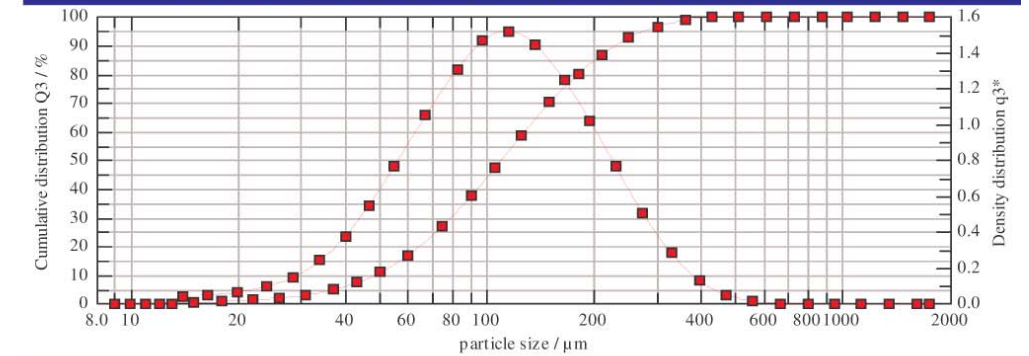

GRANUREX GX-30 DRY POWDER LAYERING

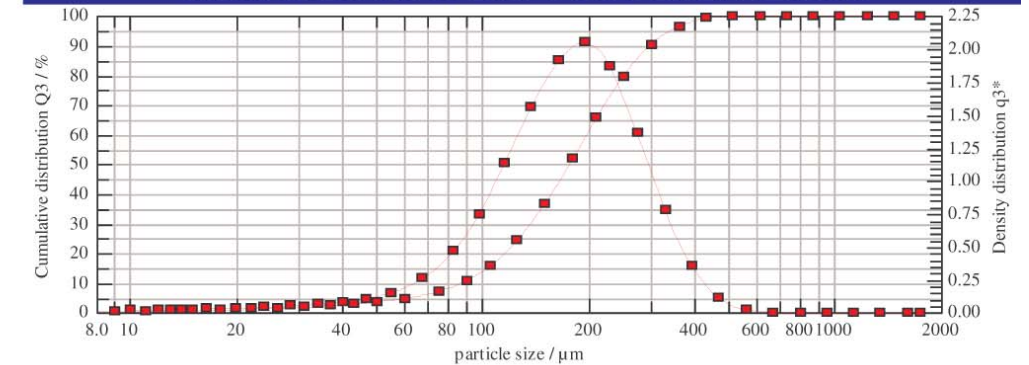

MICRONIZED ACETAMINOPHEN (RAW API)

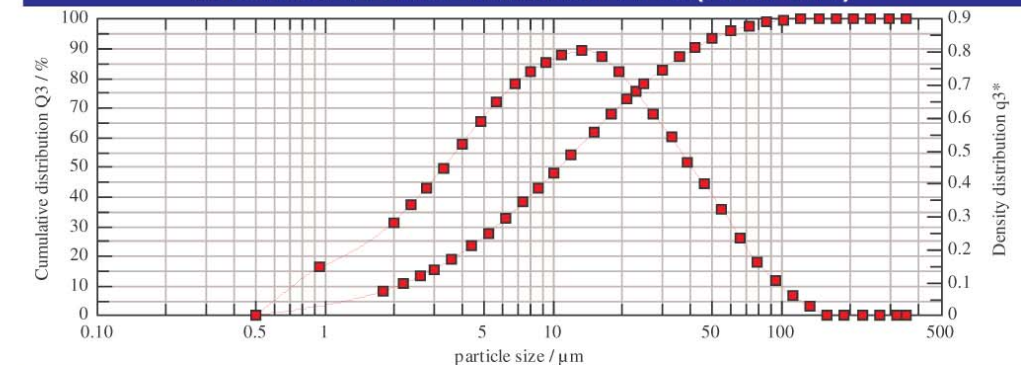

CONCLUSIONS

Spheronization of API via granulation and powder layering processes in the Granurex GX-30 are shown to make very small beads with high active content well suited for further coating. Efficiency of transfer is high, evidenced by the yields. Losses typically seen when using finely divided API are minimized by the novel rotor design, the location of the spray gun and the precise control of process air volume.

ACKNOWLEDGEMENT

Alan Pieper at Sympatec for providing particle analysis via the QICPIC and HELOS & RODOS systems.